

Tolerance		Material
0-30	± 0,1	Steel
30-120	± 0,15	Surface treatment
120-315	± 0,2	

Item
Cemage ApS Capto element
Bestillingsnr: 100 – 3383 – 40

This document contains information and data that is protected by Danish and international law. Any industrial property right contained in this document is and shall remain the proprietary right of Trelleborg Sealing Solutions Helsingør A/S. Neither receipt nor possession hereof confers or transfers any right, including the right to reproduce, use or disclose the information or data contained herein, in whole or in part, except with our written permission.

Scale	Drawn by	CSC	Drawing no.
1:1	Date		
		18-12-2013	
			Inventor 2012

Längdmått enligt ISO 2768-m	Tillåtna avvikelser
Basmått	Klass (medel)
0,5 - 3	±0,1
(3) - 6	±0,1
(6) - 30	±0,2
(30) - 120	±0,3
(120) - 315	±0,5
(315) - 1000	±0,8
(1000) - 2000	±1,2
(2000) - 4000	±2

Not.	Ändring och/eller medd.nr	Datum	Inf.	Godk.

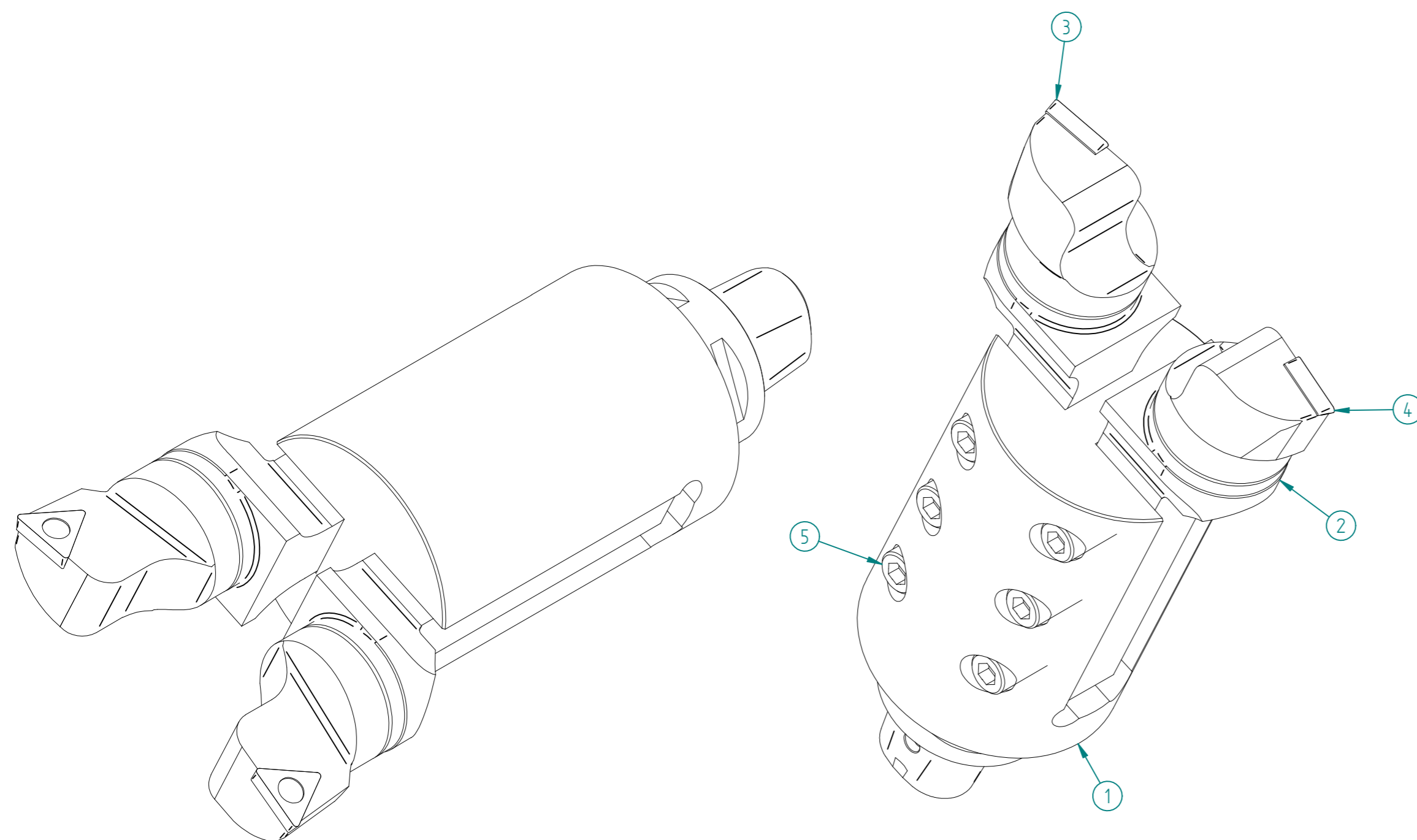
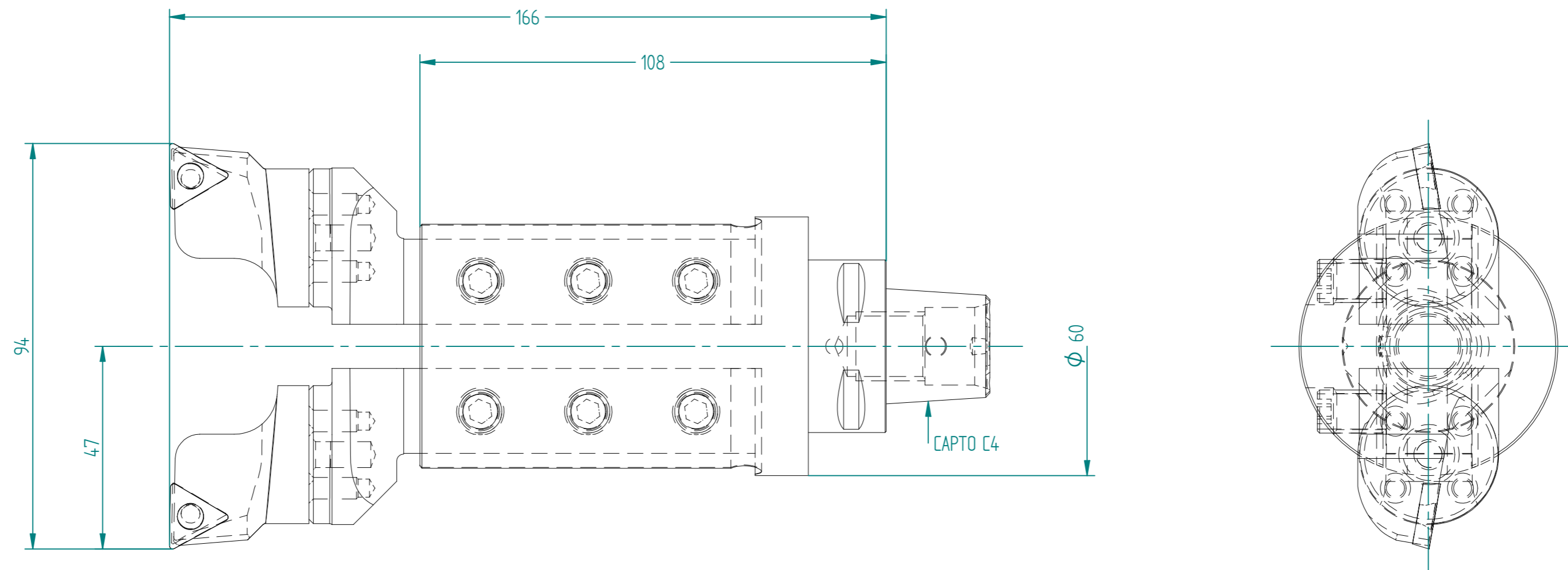

1	1	Blanks C4-NR-060165-B / Sandvik / MOD STANDARD	SV211216-1	Principal drawing	Sandvik	
2	2	Adapter rektangulärt skaft	570-32NG-2020	Principal drawing	Sandvik	
3	1	CoroTurn® 107 huvud	570-STFCL-32-16	Principal drawing	Sandvik	
4	1	CoroTurn® 107 huvud	570-STFCL-32-16	Principal drawing	Sandvik	
5	6	Insexskruv / M10	3214 010-459	Principal drawing	Sandvik	
Det.nr	Ant.	Benämning	Artikel	Anm.	Fabrikat	
Solid Edge	Ritad Joakim E	Godk. In Review	Filnamn SV211216 SAMMANSTÄLLNING.dft	Rev. -	Datum 2021-12-20	
Cemage ApS					Offertritning	Ersätter
						Ritn.nr SV211216

Langdmått enligt ISO 2768-m	Tillåtna avvikelser
Basmått	Klass (medel)
0,5 - 3	±0,1
3 - 6	±0,1
6 - 30	±0,2
30 - 120	±0,3
120 - 315	±0,5
315 - 1000	±0,8
1000 - 2000	±1,2
2000 - 4000	±2

Not.	Ändring och/eller medd.nr	Datum	Inf.	Godk.
------	---------------------------	-------	------	-------

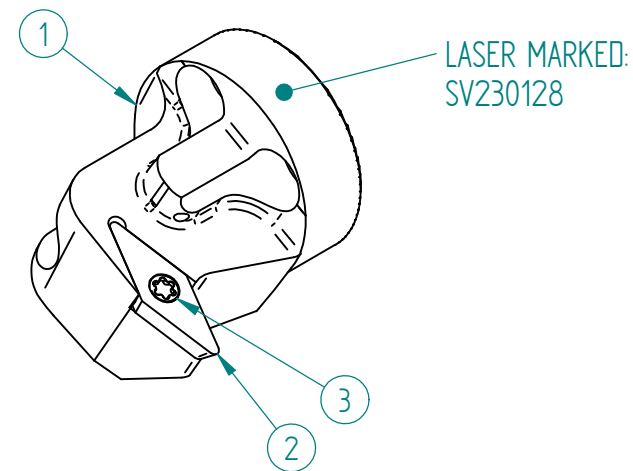
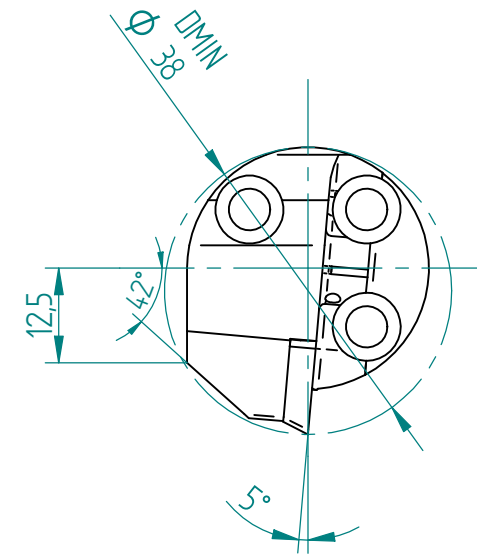
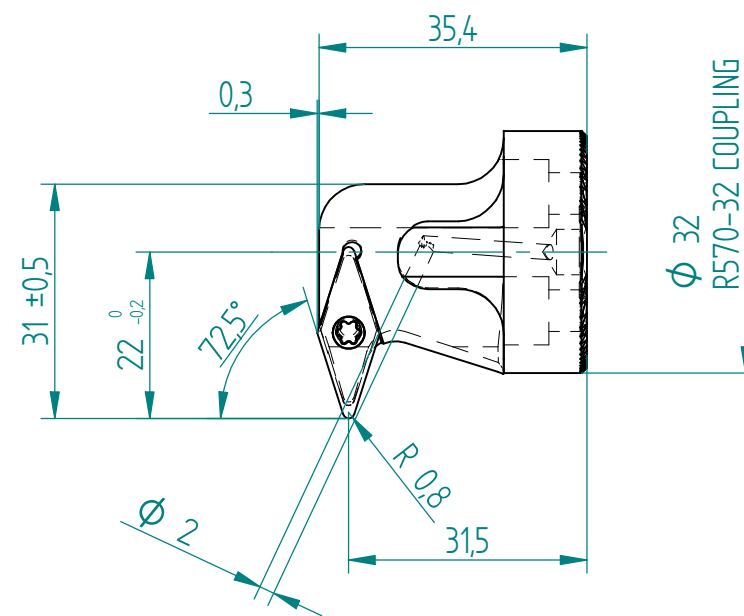

Weight: 0,13 Kg

3	1	Skärskruv	5513 020-24	M3	Sandvik
2	1	INSERT	VCGT 130308F-AL:HF7	PRINCIPAL DRAWING	DORMER PRAMET
1	1	CUTTING HEAD - RIGHT	SV230128	BLANKS R570-324022B	Sandvik
Det.nr	Ant.	Benämning	Artikel	Anm.	Fabrikat
Solid Edge	Ritad Joakim E	Godk. In Review	Filnamn SV230128 Cutting Head 570-32-Right VCGT130308.dft	Rev. -	Datum
CEMAGE ApS		OFFERT/CUTTING HEAD RIGHT			Ersätter
					Ritn.nr SV230128

Langdmått enligt ISO Z768-m	Tillåtna avvikelser
Basmått	Klass (medel)
0,5 - 3	±0,1
3 - 6	±0,1
6 - 30	±0,2
30 - 120	±0,3
120 - 315	±0,5
315 - 1000	±0,8
1000 - 2000	±1,2
2000 - 4000	±2

Not.	Ändring och/eller medd.nr	Datum	Inf.	Godk.
------	---------------------------	-------	------	-------

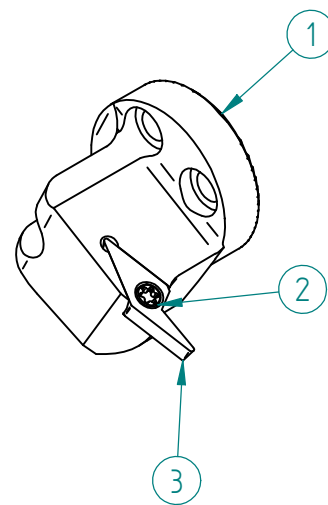
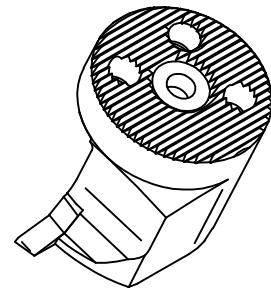
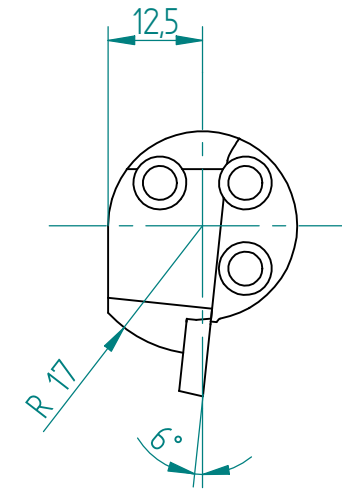
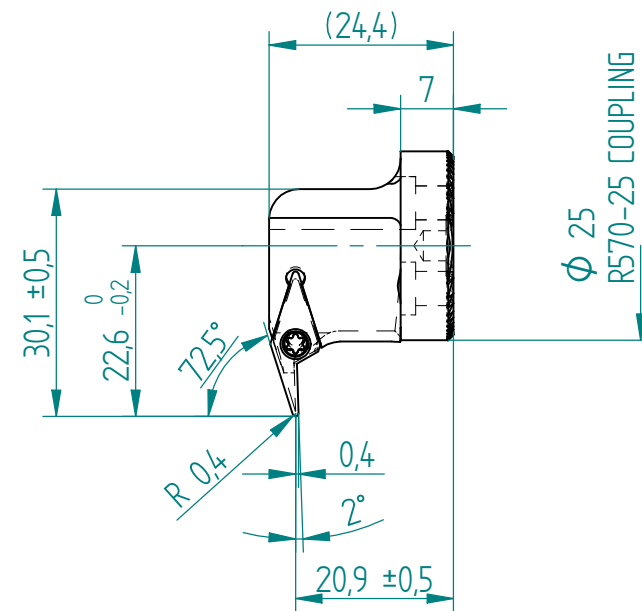

FOR CUTTING IN PTFE (PLASTIC)

3	1	CUSTOM INSERT/BLANKS VCGT110304	VCGT110304 ID		Cemage ApS
2	1	Skärskruv	C02506-T07	M 2,5	Seco
1	1	Stålämne med CoroTurn®-koppling	R570-252517B		Sandvik
Det.nr	Ant.	Benämning	Artikel	Anm.	Fabrikat
Solid Edge	Ritad Joakim E	Godk. In Review	Filnamn SV230315-1 Cutting Head 570-25-Right VCGT 110304 ID.dft	Rev. -	Datum 2023-03-20
		CEMAGE ApS		OFFERT/CUTTING HEAD RIGHT	
					Ersätter
					Ritn.nr SV230315-1